

# Intake/Exhaust Wall-mounted Louvres

## CWS-COMBI



### Description

The CWS-COMBI air intake and exhaust vent is designed to admit fresh air while exhausting waste indoor air through a unit with a small footprint which prevents the mixing of the air flows. This unit is mainly used in mechanical ventilation systems with heat recovery where there is not enough space for the ductwork of separate air intake and exhaust units installed with a sufficient distance from one another. The product is made of galvanised steel powder-coated in RAL9010. Can be painted in any RAL colour. It is fitted with a drip cap to prevent condensation from fouling the building exterior wall. There is a wire mesh to prevent leaves and other debris into the ventilation ducts. Specify the version when ordering: right-hand or left-hand.

#### Available versions:

- CWS-COMBI-...-L – left-hand version
- CWS-COMBI-...-R – right-hand version

left-hand version



right-hand version



#### Available materials - Product code examples

CWS-COMBI... – galvanized steel sheet with powder-coated finish in RAL9010

#### Product code example

Product code: CWS-COMBI 26 - 150 - L

distance between ports \_\_\_\_\_  
 port diameter \_\_\_\_\_  
 left-hand version \_\_\_\_\_

### Dimensions

The figure shows a right-hand version

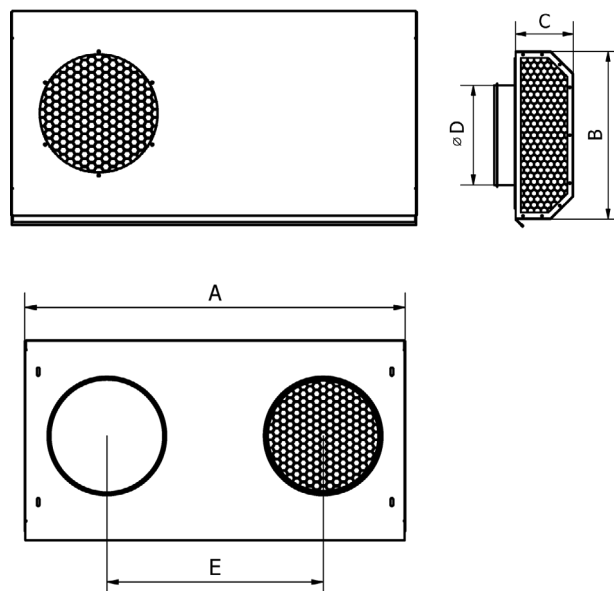

Indeks	A	B	C	D	E
CWS-COMBI26-150	508	290	115	160	262
CWS-COMBI30-200	670	337	115	200	300

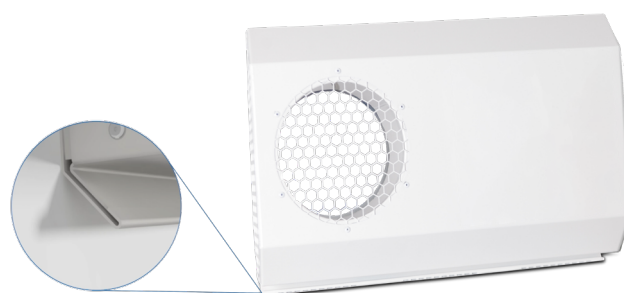

Drip cap prevent condensation from fouling the building exterior wall



# Intake/Exhaust Wall-mounted Louvres

## CWS-COMBI

### Technical data

The volumetric flow rate,  $q$  (l/s or m<sup>3</sup>/h), and total pressure loss,  $P_t$  (Pa), can be read from the charts below:

Volumetric flow rate vs. total pressure loss – air intake duct

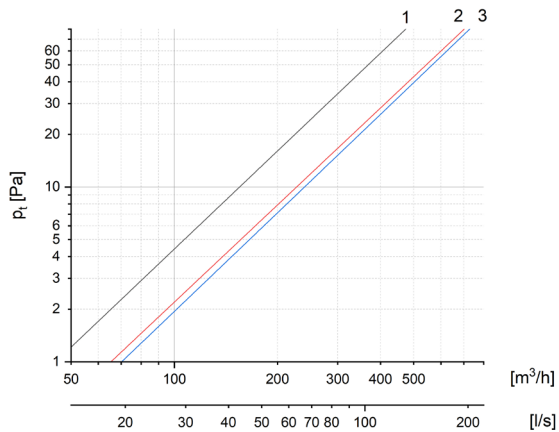

Volumetric flow rate vs. total pressure loss – air exhaust duct

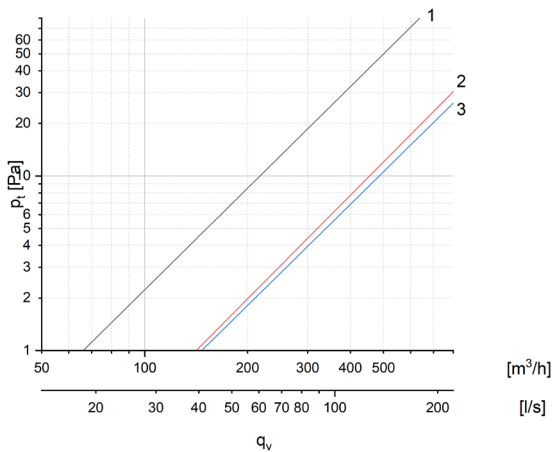

The chart lines represent:

1 – CWS-COMBI26-160

2 – CWS-COMBI30-200