

Supply air valve OPT-series

OPT-series, supply air valve



Supply air valve OPT-series



OPT is a round valve with aerodynamically design with good characteristics in terms of noise level, air flow capacity and pressure drop. The valve is mounted in a ceiling or a wall and is intended for ventilation systems with a relatively high pressure drop. The valve can be equipped with air directional units (180 degrees) in the desired direction. The design of the valve and a gasket of moltoprene prevents soiling.

Attachment, adjustment and detachment

The valve is pushed into the frame. The cone is screwed out or in the number of turns giving the gap an opening in mm corresponding to pressure drop and the desired air flow according to the diagram. The pressure drop can be checked by using a suitable measuring device. When dismantling, the valve is pushed sideways and then pulled out.

Material

The valve is made of polypropylene plastic that can withstand temperatures up to 120 degrees Celsius. The material keeps its color over time and is recyclable.

Cleaning

The valve is cleaned with normal detergent.

Color

Standard white (RAL 9003). Other colors can be delivered by arrangement.

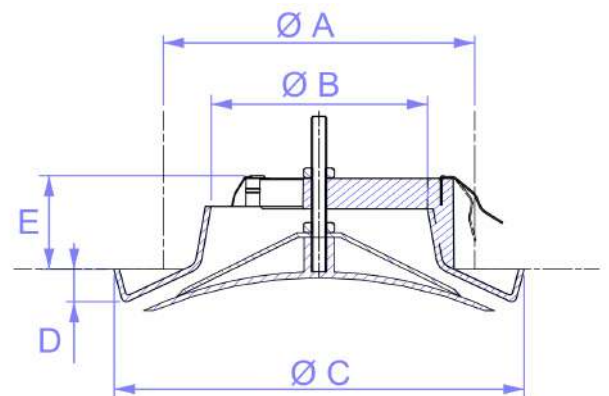

OPT	Ø A	Ø B	Ø C	D	E	Weight
80	80	46	120	20	40	80 gr
100	100	74	150	17	40	110 gr
125	125	93	180	20	40	182 gr
150	150	113	205	23	35	224 gr
160	160	113	205	23	35	224 gr
200	200	165	245	22	45	358 gr

Specifications

Capacity charts

OPT-125

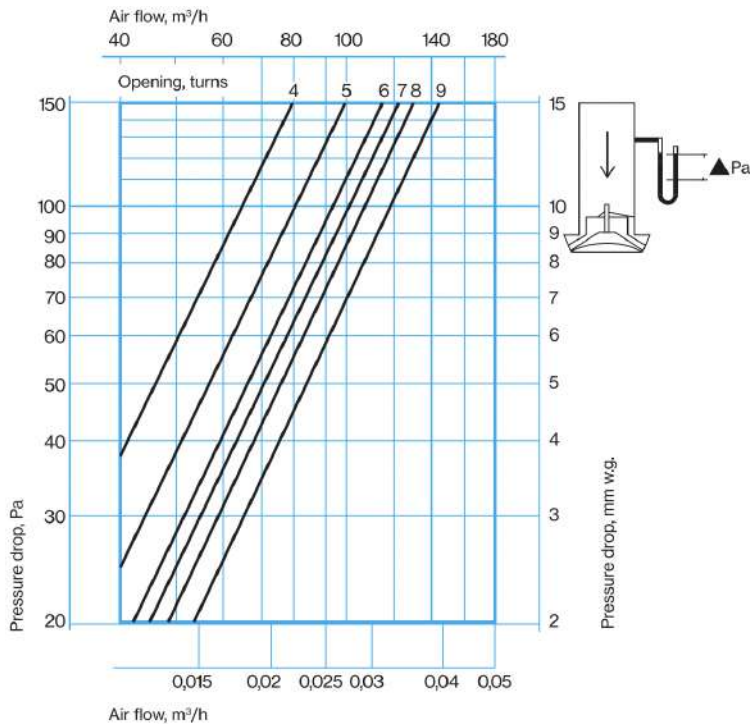

Distribution pattern at 70m³/h at 7 mm and 30 dB(A)

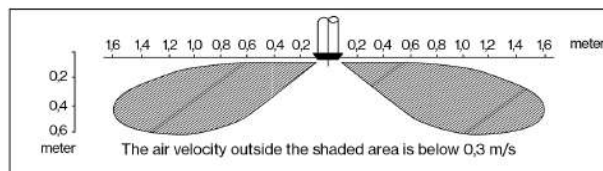

Sound Attenuation dB(A)±1

Turns	0	4	5	6	7	8	9
1 valve	14,0	8,0	8,0	7,5	7,0	6,5	6,0
2 valve	15,0	13,5	12,5	12,0	11,5	11,0	10,5

K-Factor

Number of openings (rotations), n

2	4	6	8	10	15	20
0.59	0.94	1.31	2	2.26	2.67	3.81

Sound

Correction of the sound level at different frequencies

63	125	250	500	1000	2000	4000	8000
0	1	-2	-5	-5	-5	-8	-18

Specifications

Capacity charts

OPT-150

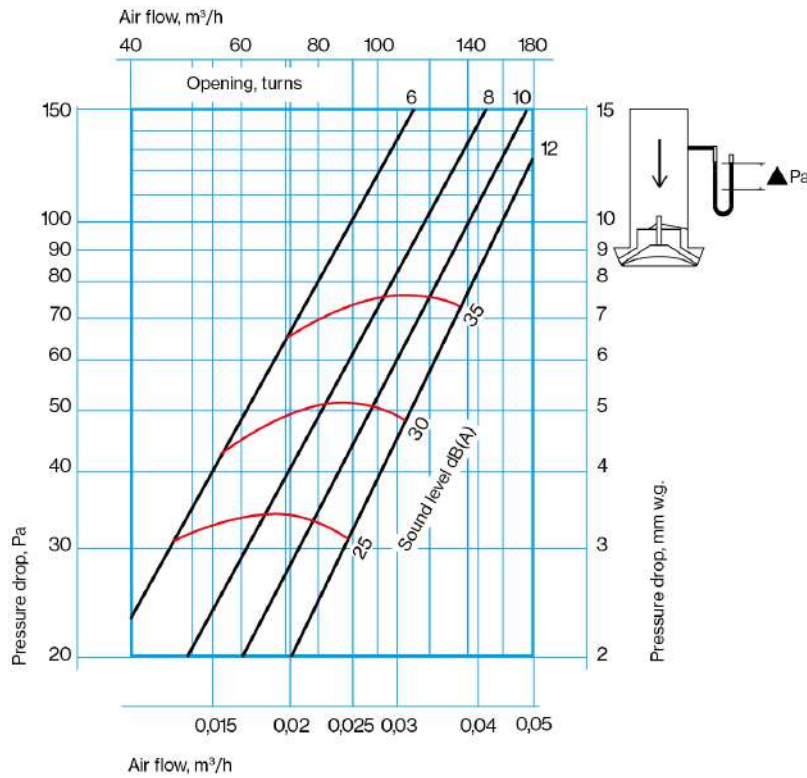

Distribution pattern at 110m³/s at 4.8 mm and 30 dB(A)

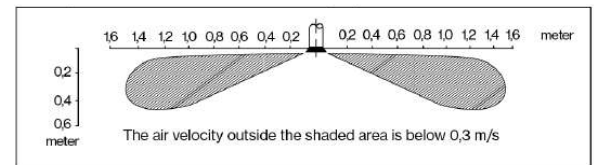

Sound Attenuation dB(A)±1

Turns	0	6	8	10	12
1 valve	14,5	6,5	6,0	6,0	6,0
2 valve	18,0	12,0	10,5	9,5	9,5

Blanking- off segments are supplied as accessories and should be fitted for the required change in air flow direction in one, two or three openings of the valve disc. On a change in direction, the air flow rate and sound level at constant pressure drop will be as tabulated below:

Number of segments	Air flow rate	Sound level
1	O x 0,83	L - 1
2	O x 0,67	L - 3
3	O x 0,50	L - 4

Ex 5,5 mm w.g., 8 turns. Q = 88 m³/h.
L = 32 dB(A).
With three segments:
Q = 88 x 0,50 = 44 m³/h
L = 32 - 4 = 28 dB(A).

Sound

Correction of the sound level at different frequencies

63	125	250	500	1000	2000	4000	8000
1	-2	-2	1	-1	-3	-9	-18

K-Factor

Number of openings (rotations), n

2	4	6	8	10	15	20
1.58	2.38	3.06	3.7	4.37	6.23	8.71

Specifications

Capacity charts

OPT-200

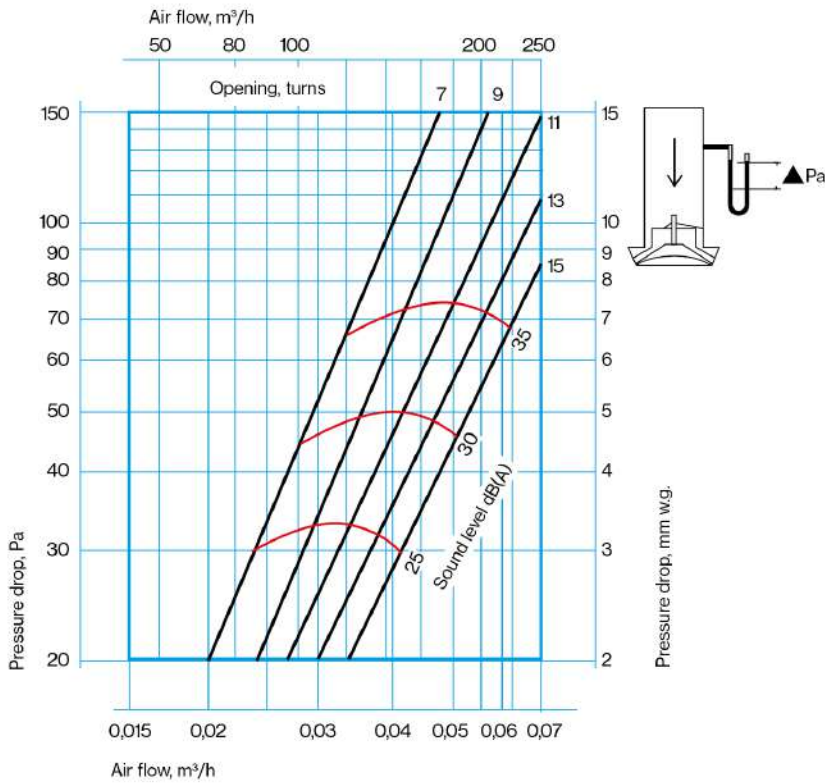

Distribution pattern at 110m³/s at 4.8 mm and 30 dB(A)

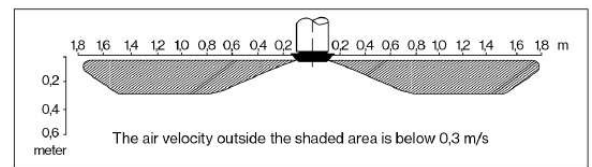

Sound Attenuation dB(A)±1

Turns	0	7	9	11	13	15
1 valve	15,5	6,5	6,0	5,5	5,5	5,5
2 valve	19,0	12,5	11,0	10,5	9,5	9,5

Blanking-off segments are supplied as accessories and should be fitted for the required change in air flow direction in one, two or three openings of the valve disc. On a change in direction, the air flow rate and sound level at constant pressure drop will be as tabulated below:

Number of segments	Air flow rate	Sound level
1	O x 0,83	L - 0
2	O x 0,67	L - 2
3	O x 0,50	L - 4

Ex 6,5 mm w.g., 7 turns. Q = 120 m³/h.
L = 35 dB(A).
With two segments:
Q = 120 x 0,67 = 80,4 m³/h

Sound

Correction of the sound level at different frequencies

63	125	250	500	1000	2000	4000	8000
-6	-3	-6	-1	0	-4	-9	-16

K-Factor

Number of openings (rotations), n

2	4	6	8	10	15	20
1.93	3.2	4.14	5.03	5.84	8.87	11.6